



The Green Solution

3" SureSeal[®] MODEL #SS3009V

INLINE FLOOR DRAIN TRAP SEALER



Specification: SureSeal model SS3009V Waterless Inline 3" Drain Trap Seal. HDPE (High Density Poly Ethylene) housing with proprietary heavy duty silicone diaphragm and soft EPDM rubber sealing gasket. Floor rating ASSE 1072 AF GW.

Function: Installs into the outlet of drain bodies, or drain hubs to protect the trap seal from evaporation. Creates a physical barrier that blocks sewer gases and their odors from escaping. Provides waterless trap seal protection equivalent to water based trap primers.

- **New Construction:** Used as a trap primer replacement or in conjunction with a trap primer to provide protection against escaping sewer gases. Eliminates the need to repair/replace trap primers when they fail.
- **Retrofit:** Used in situations where trap primers have failed or where trap primers were never installed.

Benefits: Simple to install, eliminates the need for complex, time consuming, and expensive repairs. ECO friendly providing 100% water savings efficiency over traditional methods.

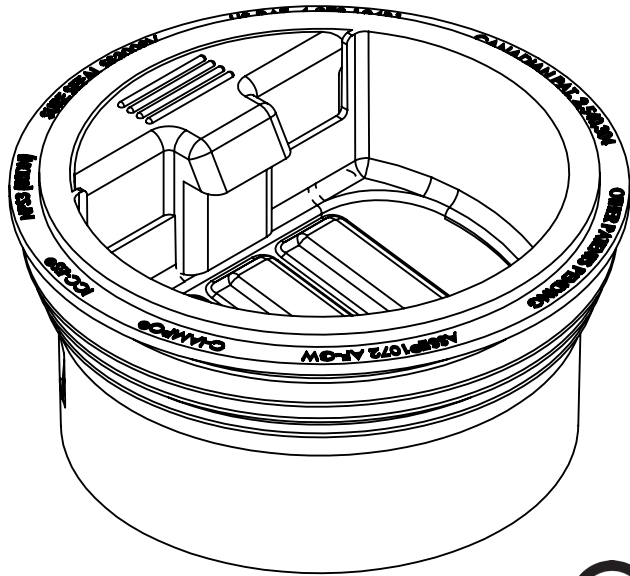
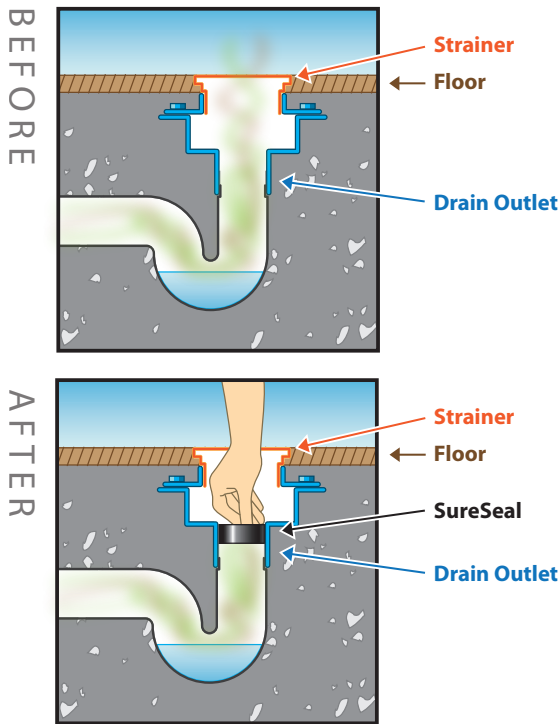

ICC-ES Listed: PMG-1070 IAPMO Listed: C-4165

U.S. Patent 9,010363

Other Patent Pending

