

**Features**

- 29<sup>51</sup>/<sub>64</sub>" (757) x 19<sup>45</sup>/<sub>64</sub>" (500) x 9<sup>29</sup>/<sub>32</sub>" (252) kitchen sink.
- Single compartment.
- Sink is glazed on all four exterior sides. Suitable for undermount, flush mount, built-up, or above counter installation.
- Farmhouse style with a wrap around 9<sup>29</sup>/<sub>32</sub>" (252) high apron front.
- Front panel is reversible. Fluted pattern on one side, plain front (no pattern) on other side.
- Made of highest grade fireclay, which is clay heated to an extremely high 1600° making the sink hard and durable, with a beautiful high shine.
- Durability of fireclay means it is resistant to scratches and chips and is easy to clean.
- Extra deep bowl means more room for big pots.
- Fits 36" (914) minimum base cabinet width.

**Components**

Product includes:  
Installation Instructions

**Options**

- 2210R Covered Sink Strainer
- 4010 Covered Disposer Strainer

**Warranty**

- Lifetime Limited Warranty



**Specified Model**

Model	FUSF302010
Overall Dimensions	L29 <sup>51</sup> / <sub>64</sub> " x W19 <sup>45</sup> / <sub>64</sub> " x D9 <sup>29</sup> / <sub>32</sub> " 757 x 500 x 252
Bowl Dimensions	L27" x W17 <sup>7</sup> / <sub>8</sub> " x D9 <sup>1</sup> / <sub>2</sub> " 686 x 454 x 241
Drain hole:	3 <sup>5</sup> / <sub>8</sub> " (92mm)
Shipping Weight	96 lbs. 41 kg
Material	Fireclay
Color	White
Installation	under counter mounted
Required	template, included

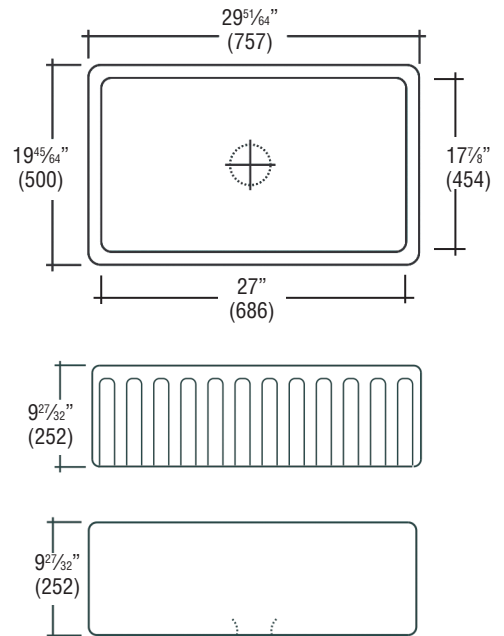

**Codes/Standards**

ASME A112.19.3/CSA B45.4

**Notes**

Install this product according to the installation instructions.