

FEATURES

- Close coupled 2-pc. HET toilet. Combination elongated front bowl and tank, less seat.
- 12" (305mm) rough-in.
- Vitreous china.
- High efficiency (1.28 gpf/4.8 Lpf).
- Gravity feed, siphon action bowl.
- 2" fully-glazed trapway.
- 16-1/2" comfort height.
- Chrome trip lever.
- 2 color-matched bolt caps.
- 5 Year Limited Residential Warranty / 1 Year Commercial Warranty
- Meets strict flushing performance criterion established by the EPA (environmental protection Agency) WaterSense program
- High efficiency toilets use at least 20% less water than standard 1.6 GPF toilets
- This product can help a building earn Water Efficiency points in the LEED Green Building Rating System™

COLORS

- White

OPTIONS

- Tank with right-hand trip lever.

Specified Model

	MODEL NO.	DESCRIPTION	Length	Width	Height
COMPLETE TOILET KITS					
<input type="checkbox"/>	TBT-1555	EL Bowl & LH Tank	30"	18 1/8"	31 1/10"
<input type="checkbox"/>	TBT-1555-01	EL Bowl & RH Tank	30"	18 1/8"	31 1/10"
INDIVIDUAL COMPONENTS					
<input type="checkbox"/>	TB-1555	Elongated Front Bowl	30"	14"	16 1/2"
<input type="checkbox"/>	TT-1550	Toilet Tank - LH Trip Lever	8 1/2"	18 1/8"	15 1/10"
<input type="checkbox"/>	TT-1550-01	Toilet Tank - RH Trip Lever	8 1/2"	18 1/8"	15 1/10"

To Be Specified: Color (see below)

01 White



TOILETS/LAVS

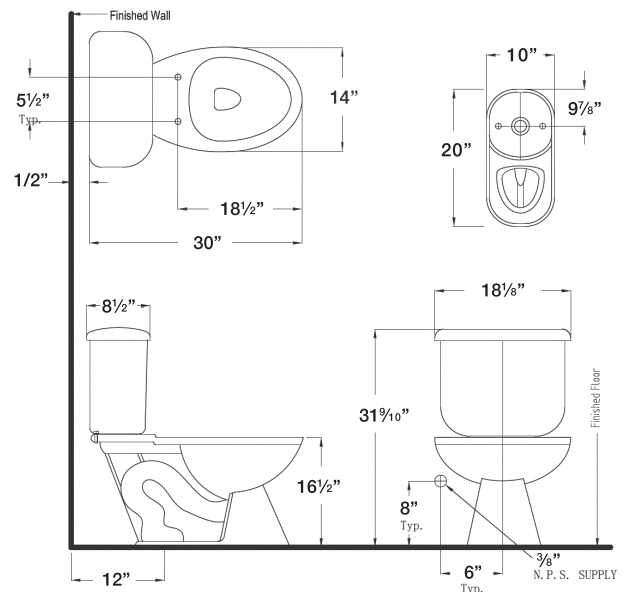

**Compliance Certifications -
Meets or Exceeds the Following Specifications**

- ASME A112.19.2M-2008/CSA B45.1-2008
- UPC®, National Plumbing Code of Canada, IPC & IRC
- EPA Water Sense Tank-Type High Efficient Toilet Specs

This toilet is designed to rough-in at a minimum dimension of 305mm (12") from finished wall to C/L of outlet. Supply not included with fixture and must be ordered separately.

Dimension shown for location of supply is suggested. For additional information refer to installation instructions supplied.